

# Department of Fisheries and Oceans

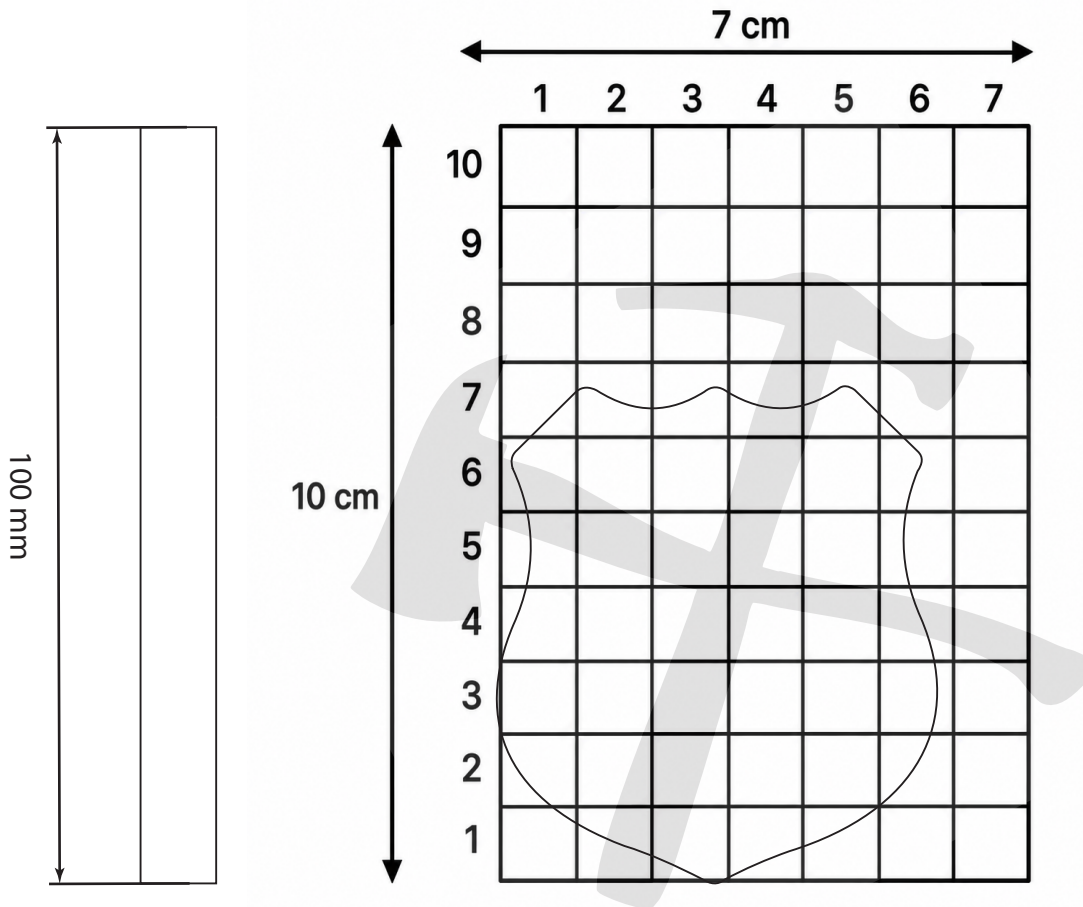

## 1. Print the PDF at 100% scale:

Please print your badge outline at actual size. You may need to open your printer's advanced settings and select "Actual Size" or "100% Scale." Do not use "Fit to Page," as this may change the size of the outline.

## 2. Confirm the printed rectangle measures 100mm:

After printing, measure the length of the rectangle with a ruler or a caliper. Make sure it measures exactly 100mm. This ensures the scale is correct and the badge will be accurate.

## 3. Place the badge over the cut-out tracing:

Place your badge over the cut-out tracing. Check that the badge fits within the cut-out, without any parts hanging over the edges.

## 4. If adjustments are needed:

If the badge does not fit as intended or if there are any sizing issues, please email us at [info@hammerandaxeleather.com](mailto:info@hammerandaxeleather.com) or message us on the badge portal for further assistance.